



Sea Gear

CHAIN SLIDING MOTOR FOR HEAVY DUTY APPLICATION



- Powerful commercial chain drive slide operator for gates up to 37 feet /11 m and 1400 lbs / 700 kg
- Gear box in oil-bath.
- Polyethylene case.
- Speed 1 feet per second.
- Slow down in opening/closing.
- Reverse on obstruction.
- Ball bearing wheels.
- Continuous cycles.
- All made with high quality source components.
- Yellow zinc metal chassis.
- Control board: GATE 1DG (Possibility to add up to 3 LOOP PLUG with different functions).
- Buzzer alarm.
- Duty Cycles*: 90 per hour.

* Duty Cycles depend on gate size and installation



Ball bearing wheels



Limit switch

CODE	DESCRIPTION	MAX LEAF WEIGHT	MAX LEAF LENGTH	MAX CYCLES / HOUR	PCS PER PALLETS
1180MECO-CSA	SEA GEAR (GATE 1 DG)	1400 lbs	37 feet	90 %	8

CONTROL BOARDS

CODE	DESCRIPTION
54001155	GATE 1 110V Replace only circuit
23023035R-CSA	GATE 1 DG Replace only circuit

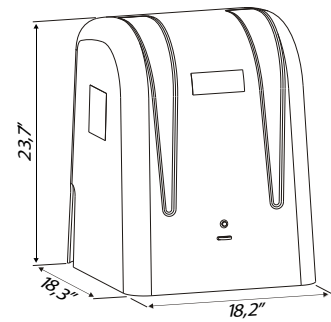

Dimensions (inches)

ACCESSORIES



23105053
STAR 500
 battery back-up
 for A.C. motors 110V

PACKAGE SEA GEAR

- N.1 Operator SEA GEAR with control board GATE 1DG
- N.20 Feet of chain (type40)
- N.1 Receiver
- N.1 Remote control 433 Mhz
- N.1 Foundation plate
- N.1 Installation accessories Kit
- N.1 Installation instructions and general notice
- N.1 Warning signboard