



# Compact 800

Listed to  
ANSI/UL 325

**OPERATOR REALIZED FOR SWING GATES (UNDERGROUND AUTOMATION) ON ANCIENT OR MODERN STYLE .MAX LEAF WEIGHT 880 Pound. MAX LEAF LENGTH 13 feet.**

## Strong, Silent & Discrete

The Compact is a one-piece unit consisting of a hydraulic pump unit close coupled to the underground gate actuator. The drive assembly fits into a purpose made gate support box **with positive stops built-in**. The pump unit casing contains the electric motor, fluid pump, distributor and hydraulic oil. The hydraulic fluid acts as both the motive force and as a coolant for the motor. Setting valve allow a perfect pressure adjustment, brake in opening and closing. Gates can be securely locked in the opened and closed position using the operators internal hydraulic system.

## Manual Release:

In case of power failure: The operator's internal hydraulic locking can be released using a special key and the gate used manually until power is restored



OPERATOR SPECIFICATION	
Supply voltage	115 Vac $\pm$ 5%
Motor current	2 A
Pump capacity	0,19 Gal
Opening time	9 sec.
Max working pressure	50 bar
Operating temperature	-43°F +131°F
Thermal protection intervention	266°F
Max leaf weight	880 Pound
Max leaf length	13 feet
Cycle/hour	30
Max opening angle	100°
Weight	30,4 Pound



DESCRIPTION	COD	LOCK TYPE	OPENING ANGLE	LEAF WEIGHT	PUMP CAPACITY
COMPACT 800 DX	121AC1R0	AC	100°	880Pound	0,19Gal
COMPACT 800 SX	121AC1L0	AC	100°	880Pound	0,19 Gal
<b>CARRYING BOX</b>	<b>12101010</b>	<b>SX</b>			
COMPULSORY ACCESSORY	12101005	DX			



**ELECTRONIC CONTROL UNIT**  
COMPACT 800 Cod. 2302A110



# Typical Installation

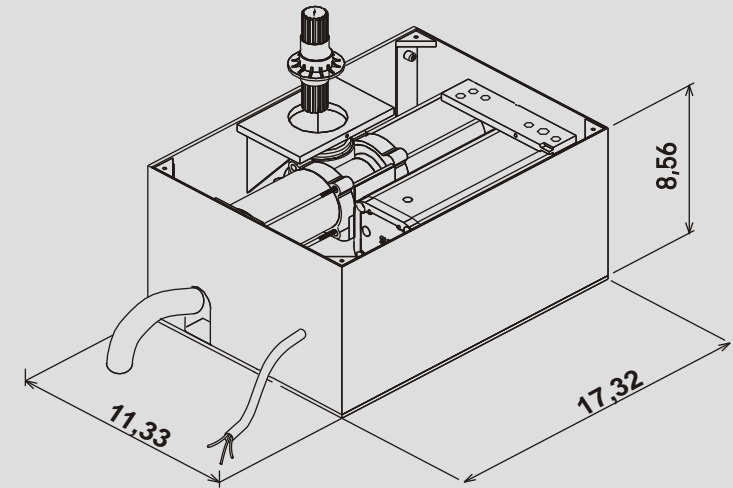
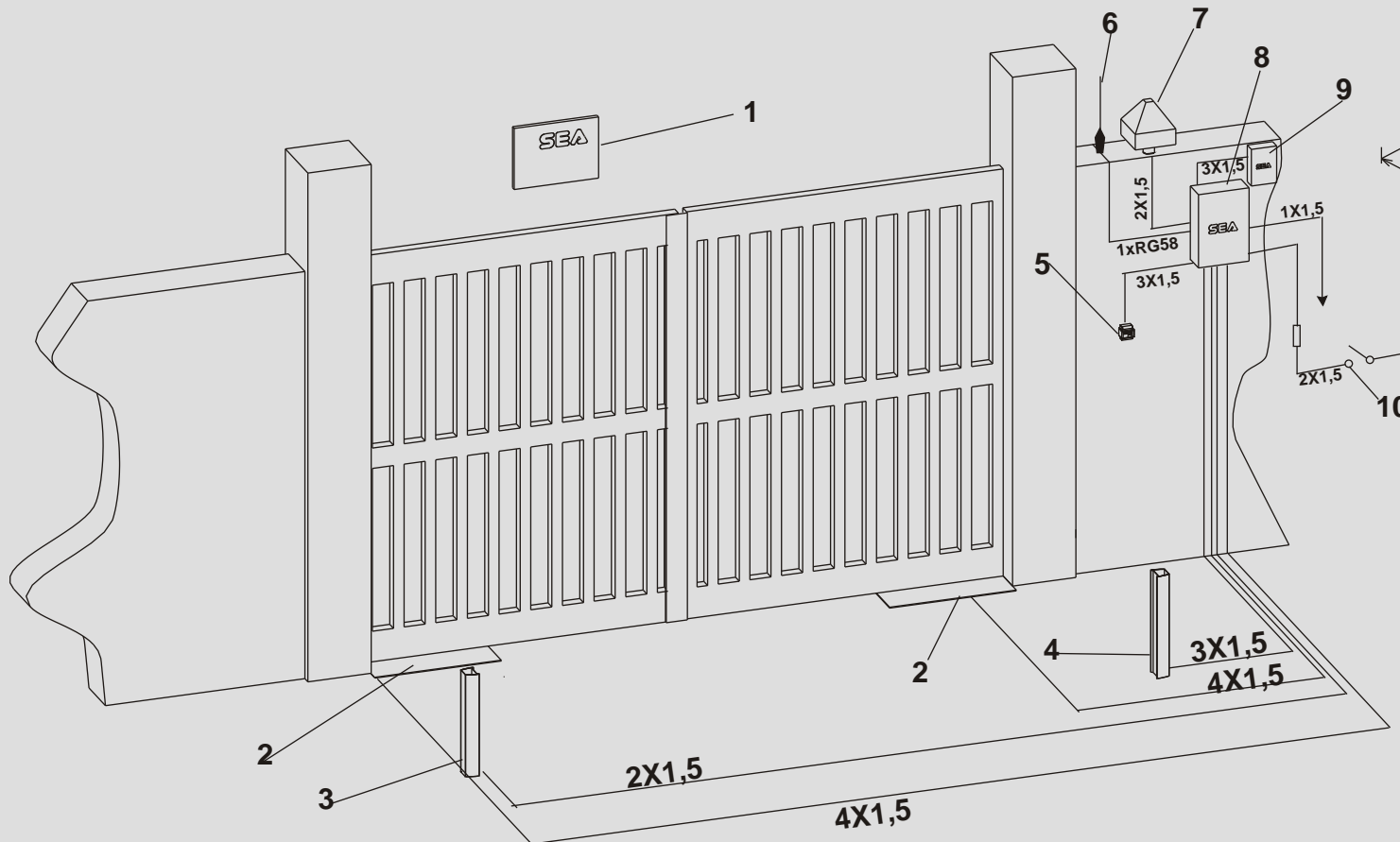
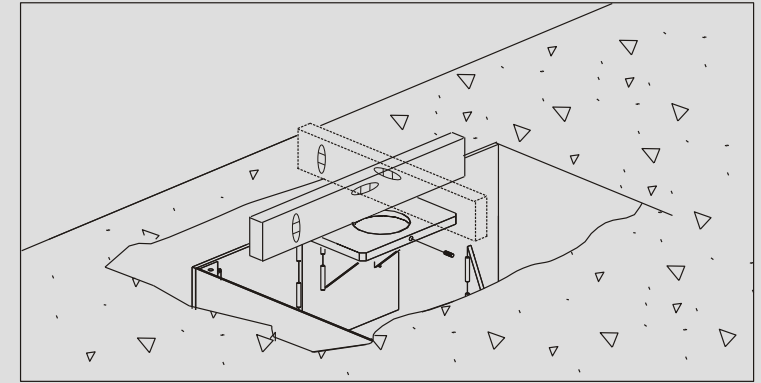
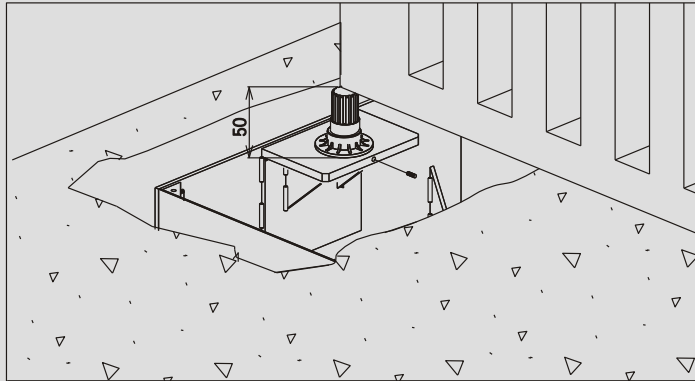
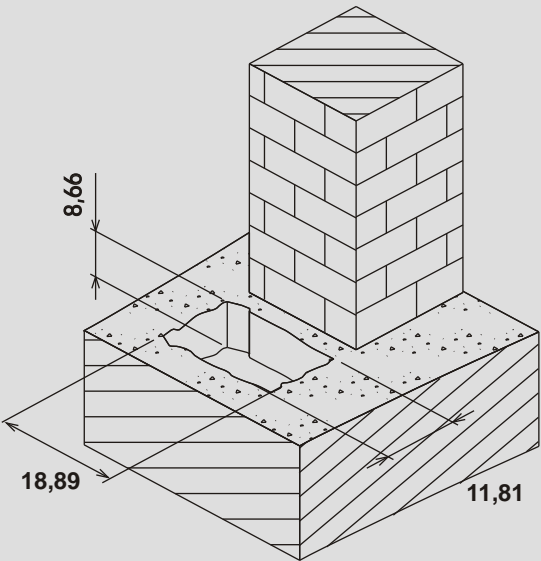

- 1) Warning plate
- 2) Operator LYRA COMPACT
- 3) Photocell SX
- 4) Photocell DX
- 5) Keyswitch
- 6) Antenna
- 7) Warning light
- 8) Electronic control unit
- 9) Radio receiver
- 10) Differential 16A-30mA