



PRE-WIRED ELECTRONIC CONTROL UNIT

(code 2302A110SW3PW)

for swing gates automation

Accessories power supply:
24V dc Max 800 mA

Trimmer regulation:
Operating times
Open pause time
Leaf delay in closing

Logics selection:
Automatic
Semiautomatic
Safety device
Dead man

Pin header connector:
Radio receiver
Auto-test cards for photocell
Garden lights cards
Traffic light card

Main features:
Reversal
Electronic lock management
Pedestrian opening
Management phot. in opening
Management of timer
Pre-flashing
Flashing lamp 115V
Flashing lamp 24V
Safety input

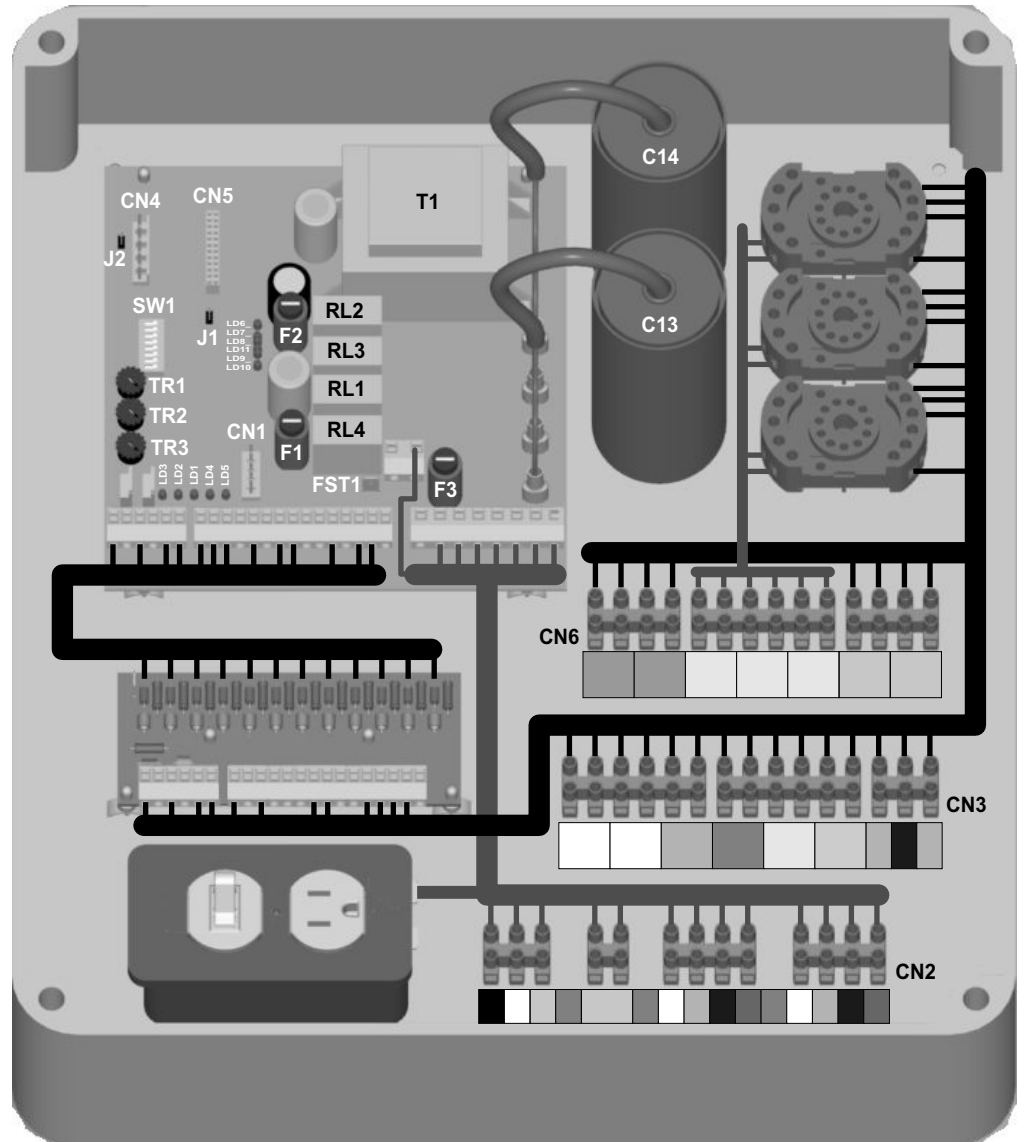

LD1: Security Led
LD2: Photocell led
LD3: Stop Led
LD4: Start Led
LD5: Pedestrian Start Led
LD6: Motor 1 Led
LD7: Motor 2 Led
LD8: Indicator Lamp Led
LD9: Flashing Lamp 24V Led
LD10: Flashing Lamp 24V Led
LD11: Electric Lock Led
F1: Electric Lock Fuse 2A (T)
F2: Accessory Fuse 1A
F3: Motor Fuse 10 A (T)
CN1: Radio Receiver Connector
CN2: Power supply, Flashing Lamp and motors terminal

CN3: Main Terminal
CN4: Photo Board Connector
CN5: Expansion Unit Connector
CN6: Security, Flashing Lamp 24V Connector
FST1: Earth Tag
RL1: Motor 1 Relay
RL2: Motor 2 Relay
RL3: Direction Relay
RL4: Lamp Relay
SW1: Programming Dip-switches
J1: Electric Lock Jumper
J2: Photo Board Jumper
TR1: Motor Run Time Trimmer
TR2: Pause Time Trimmer
TR3: Leaf Delay in closing Trimmer
T1: Transformer



CN3: Main Terminal

CN3

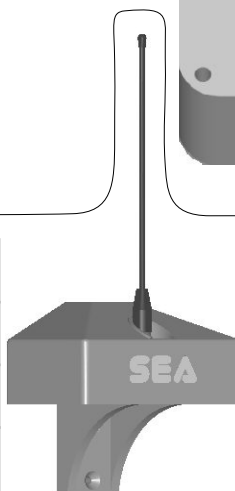
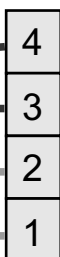
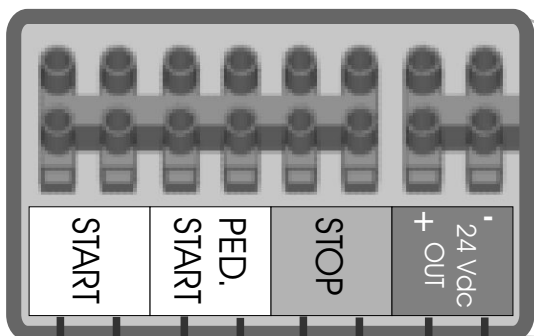
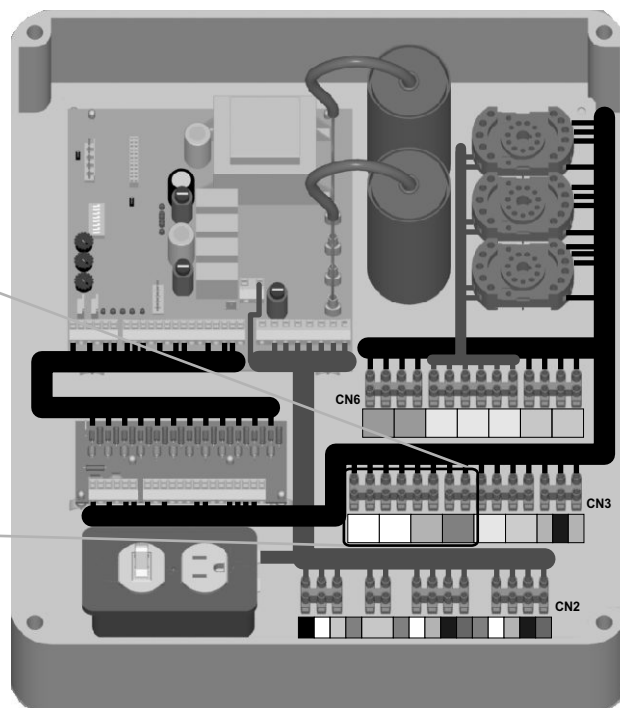

Connection of a radio receiver

This connection allows to command the total opening/closing of the automation. For the receiver connection make reference to the related instruction manual.

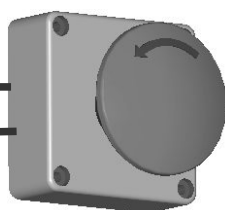

Stop Button

The pressure of this button stops the automation in whatever condition it can be it needs a start command to re-establish the movement.

Notice: if it is not used, make a link.



Pedestrian Start

To obtain a pedestrian opening (single-leaf opening) connect the key-button wires (code 23103015) as in the picture. It is possible to connect other command devices (push button board, radio receiver, decoder with keyboard).
Note1: the contact for the pedestrian opening is a N.A. contact

Note2: the pedestrian opening will be always executed on the M1 engine



Start Button

An impulse given to this entrance commands the opening/closing of the automation. It can be given by a key switch, a loop detector, a keyboard controller, etc.



CN3: Main Terminal

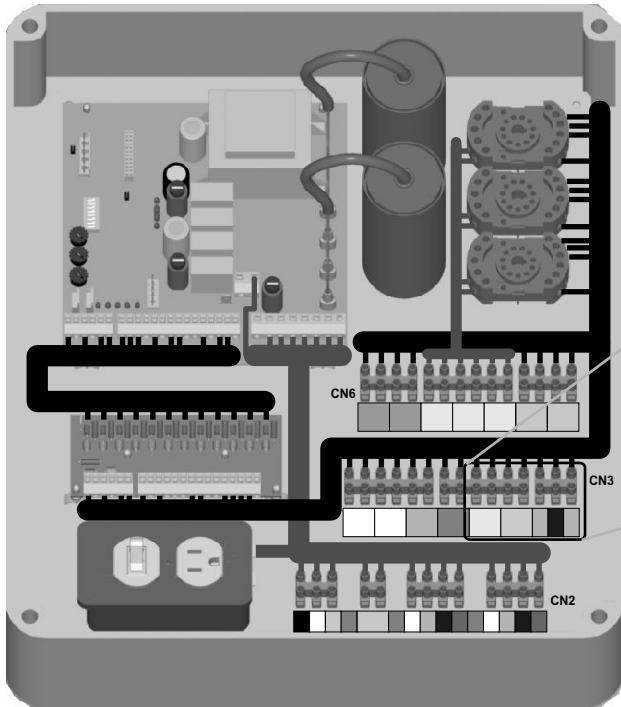

CN3

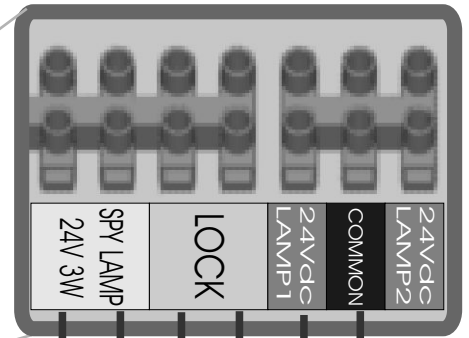

Indicator lamp

24Vdc max 3W indicator lamp exit
When the automation is in the opening or in the pause phase, the indicator stays switched on. When it is in the closing phase, it flashes.

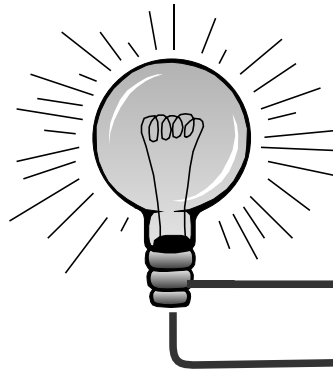

Electric lock exit

An electric lock of 12Vdc or of 24 Vdc 15W max can be connected .The electric lock activates at every opening cycle for about 1,5 sec. To activate it also in closing take off the J1 Jumper.

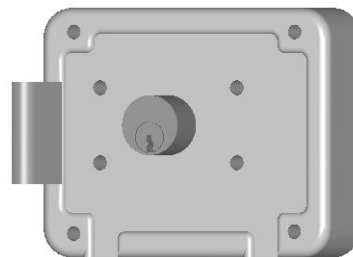

24v Flashing Lamp

For the connection of the 24v flashing lamp (code 23104011) connect the flashing lamp wires as in the picture. The pre flashing can be activated setting out Dip 5=ON of the SW1 dip switch.

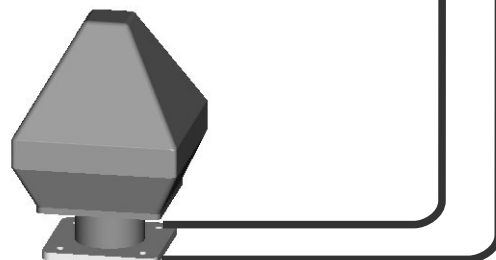



CN6: Security, Flashing Lamp 24V Connector

CN6

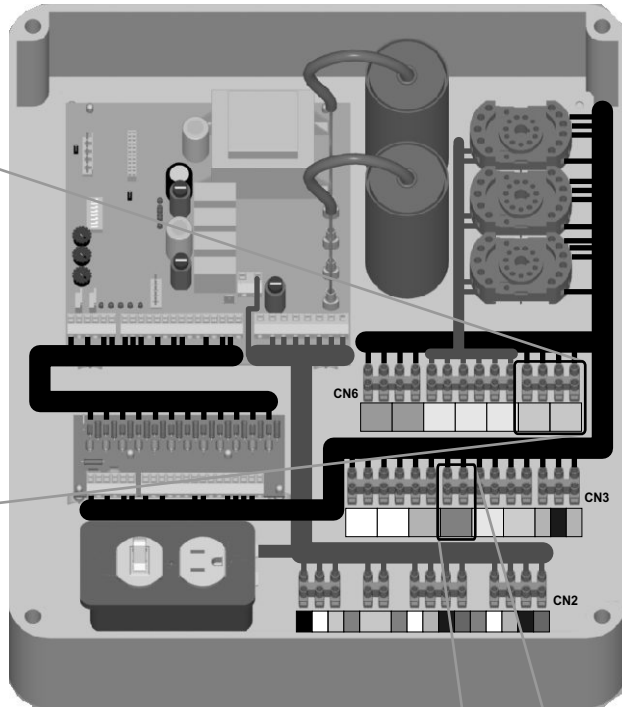
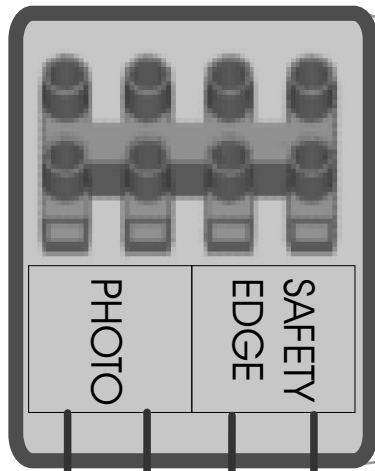

Mechanical safety edge entrance

A further safety can be obtained doing a connection, here on the side, with a safety edge (code 12705055). If activated this one reverses the gate motion for two seconds and it stops.

Notice: in case the safety entrance is not used, link terminals SAFETY EDGE through a copper wire.

Photocells connection

In case of the crossing of the photocells beam, the automation reverses the movement if in closing. In case of opening, the automation stops the movement only if the dip 6 is in ON position.

Notice: if it is not used make a link between terminals PHOTO.

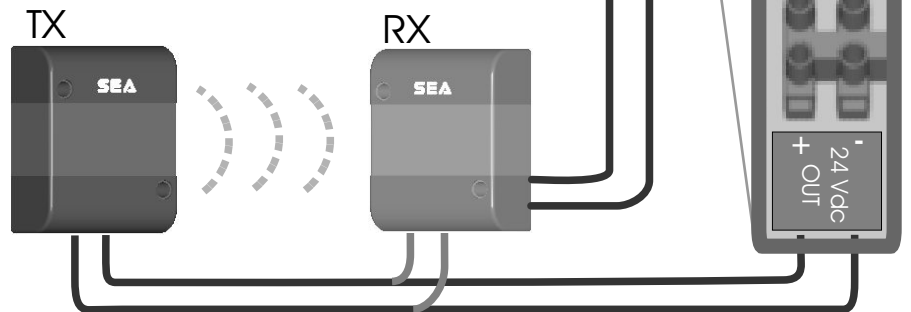



CN2: Power supply, Flashing Lamp and motors terminal

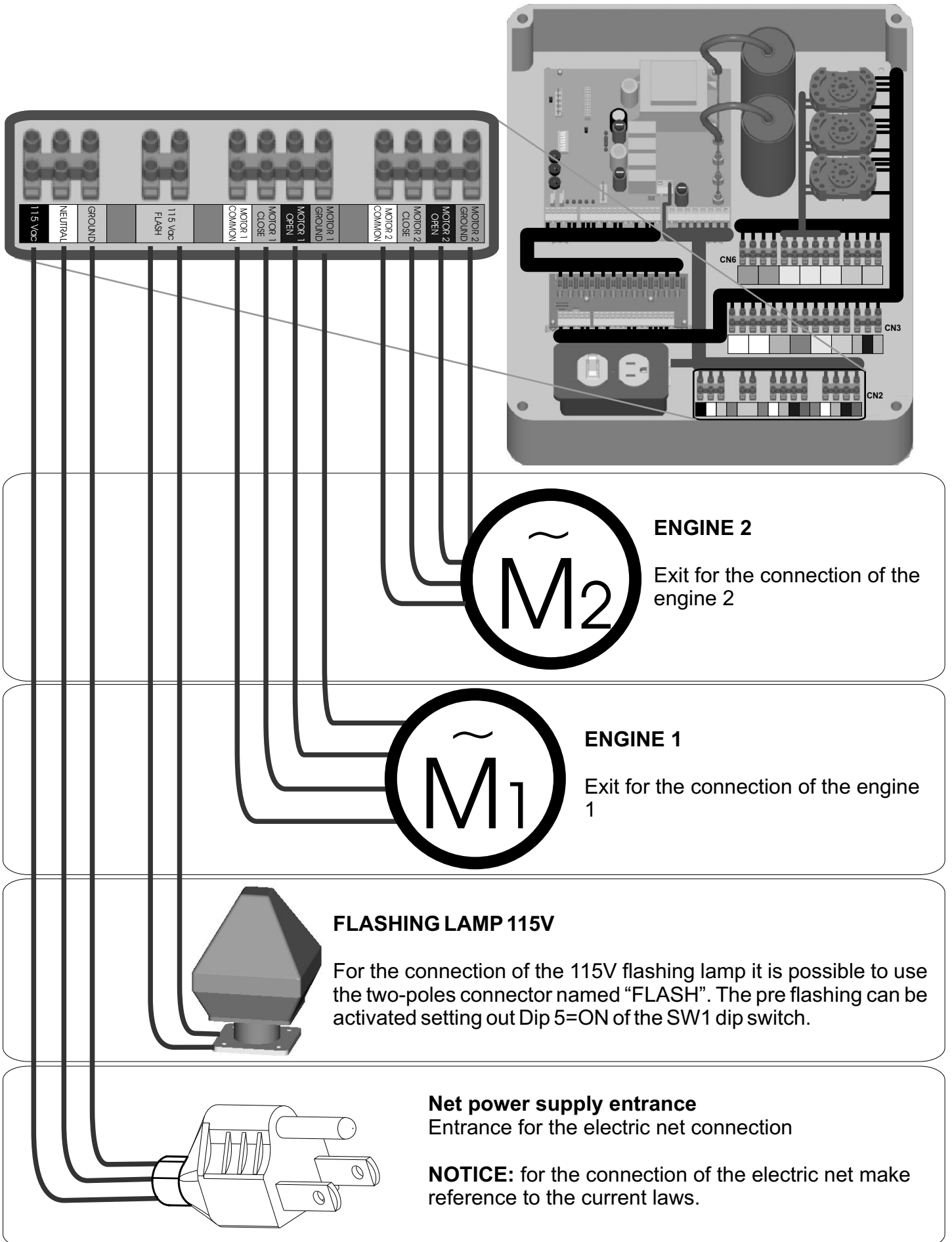



CN1: Radio Receiver Connector or decoder module

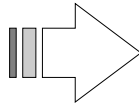
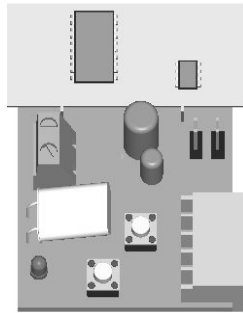

CN1

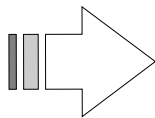
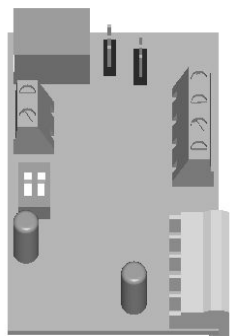
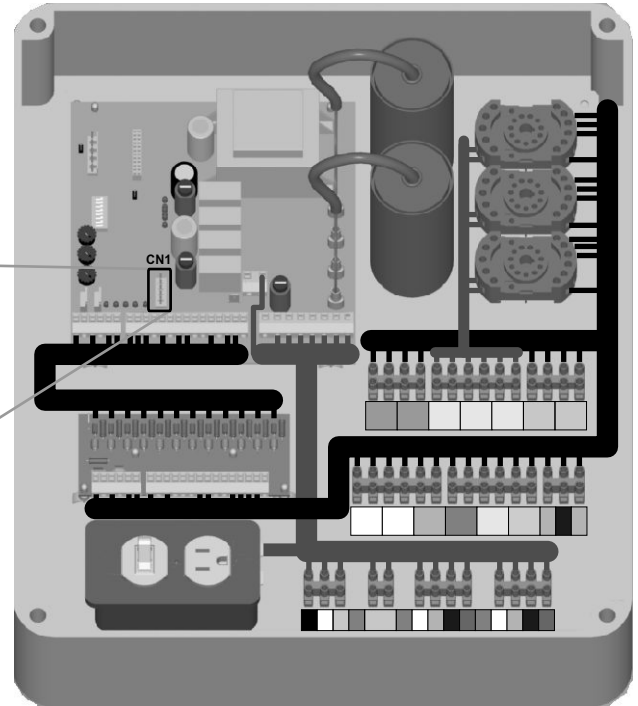
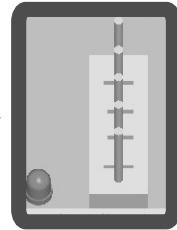

CN1

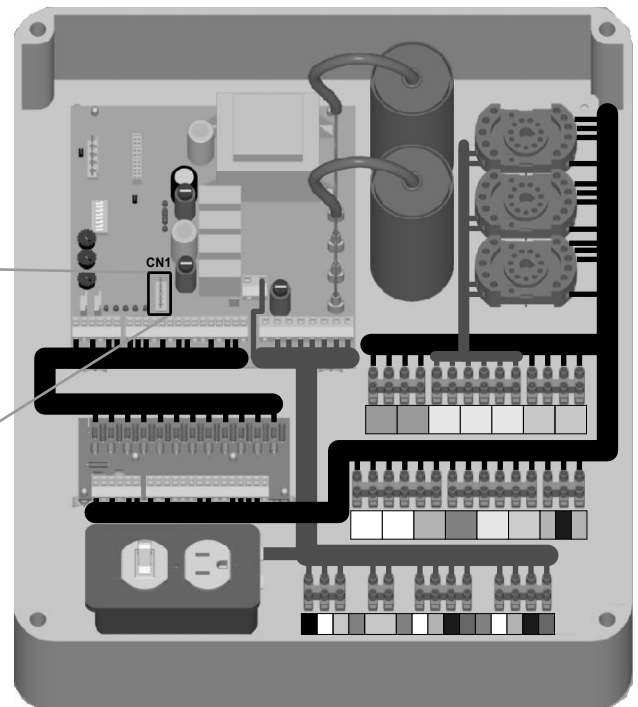
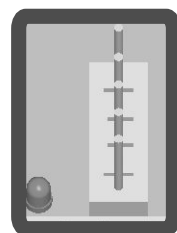

Notice: This connector is used only for the rapid connection of SEA designed products. Connector used for the rapid connection of inserting receivers or of the Decoder Module with keyboard.



SW1: Programming Dip-switch

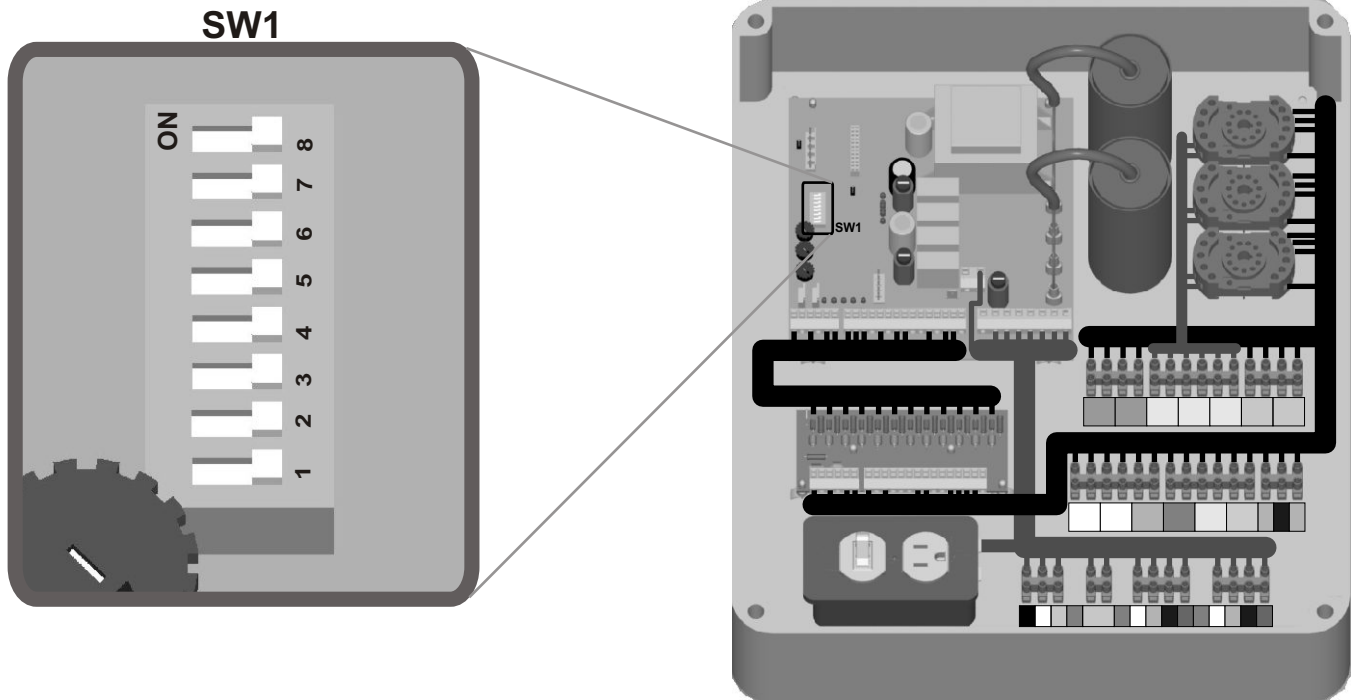

LOGIC SELECTION

It is necessary to de-power the board when setting or changing logic or feature selections. The operators run towards opening on reinstatement of the power. Logic selection is controlled by switches 1 and 2 of the block of 8 dill switches. The following logic descriptions are given with feature switches 3-8 in the OFF position. Selection of some of the features will alter the standard logic described.

* **E LOGIC** (Semi-automatic)

With the operator stopped, an impulse from a push button or radio transmitter will send the operator in the opposite direction to its last cycle. If an impulse or safety signal is received while the operator is running towards closing, the operator stops and automatically re-opens, automatically adjusting the opening run time to the time the operator has run towards closing plus approx. 2 seconds. If an impulse is received when the operator is running open, the operator stops, the next impulse will send the operator towards closing with an automatically reduced run time. Hold open safety is recommended to be used in conjunction with any logic. On A and UP logic it is essential to install either full photocell or induction loop safety.

* **A LOGIC** (Automatic).

If the operator is stopped in the closed position, a start impulse will run the operator in the opening direction for the time set after the pause time set has elapsed the operator will close, provided that the safety circuit is clear. The safety circuit will hold the operator on pause for the time set. If a start impulse is given while the operator is running towards open it is ignored. A start pulse given during the pause time erases the pause time and the operator will close. If a start impulse or safety signal is given while the operator is closing, the operator stops and re-opens with reduced run timings.

* **S LOGIC** (Security logic)

The working functions are the same as in **A Logic (Automatic)**, except for the gate movement will be inverted giving one impulse while the gate is opening.

* **UP LOGIC** (Dead Man)

The gate will open as long as the opening push button is pressed; releasing it the gate stops. The gate will close as long as the push button which is connected with the pedestrian start will be pressed; releasing it the gate will stop.

To execute the complete opening and/or closing cycles the relative push buttons must be continuously pressed.



SW1: Programming Dip-switch

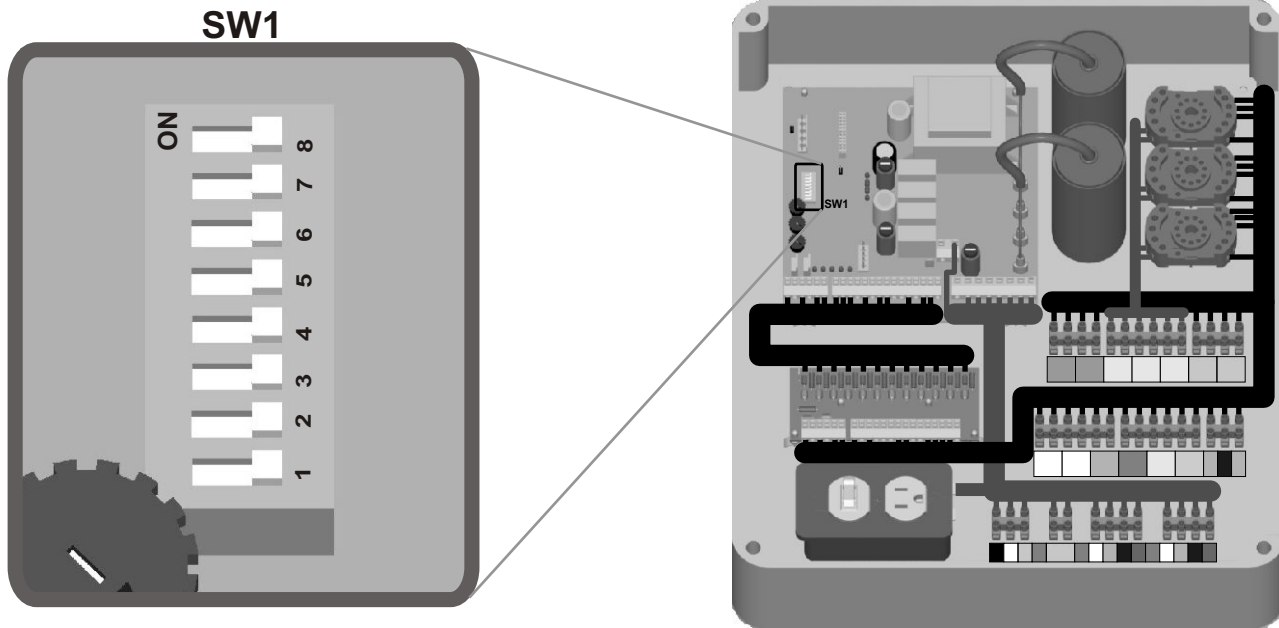

DIP	SWITCHED ON / SWITCHED OFF	DIP 1 AND 2 PROGRAMMING FOR THE CHOICE OF THE OPERATING LOGIC
1	ON	If Dip 1 and 2 are set out in this way, this equipment will operate following the security logic (S)
2	OFF	
1	OFF	If Dip 1 and 2 are set out in this way, this equipment will operate following the automatic logic (A)
2	OFF	
1	ON	If Dip 1 and 2 are set out in this way, this equipment will operate following the semi automatic logic (E)
2	ON	
1	OFF	If Dip 1 and 2 are set out in this way, this equipment will operate following the Dead Man logic (UP)
2	ON	

DIP	SWITCHED ON / SWITCHED OFF	DIP 3,4,5,6,7,8 PROGRAMMING (Activation of different Options)
3	ON	The Dip 3 function allows the equipment to activate the reversing stroke in opening (before opening, the M1 engine does a reverse movement for 1 second to facilitate the electric lock release)
4	ON	The Dip 4 function allows the equipment to activate the leaf delay in opening (the M2 engine opens with a two-seconds delay with respect to the M1 engine).
5	ON	The Dip 5 function allows the equipment to activate a pre-flashing on the flashing lamp, whether it is connected to the "FLASH" connector or to the CN3 connector (it will have a five-seconds pre-flashing which makes known the opening or closing of the gate).
6	ON	The Dip 6 function allows the equipment to manage the photocell during the opening of the gate (if the photocell registers a presence during the opening phase, the gate stops and when the photocell is free it begins to move again)
7	ON	The Dip 7 function allows the equipment to manage the presence of a timer . This option must be chosen when in parallel to the opening button it is set a timer which short-circuits it for a certain time break during which the gate must stay opened.
8	ON	The Dip 8 function allows the equipment to interrupt the pause in case the photocell registers a presence . (if the photocell registers a presence during the pause phase in opening, the pre flashing is done and the gate closes immediately without waiting for the total length of the set out pause time)



Diagnostic leds exits

LD6 (ENGINE1)

It must be normally switched off and it must switch on when the engine 1 activates (both in closing and in opening)

LD6(ENGINE2)

It must be normally switched off and it must switch on when the engine 2 activates (both in closing and in opening)

LD8 (INDICATOR LAMP)

It must be normally switched off and it must switch on when the automation is in opening or in pause phase and it must flash when it closes

LD11(ELECTRIC LOCK)

It must be normally switched off and it must switch on when the electric lock is activated (at the beginning of the opening cycle or of the closing cycle if activated)

LD9 (FLASHING LAMP 24V, LAMP 1)

It must be normally switched off and it must switch on when the automation is in movement (both in closing and in opening)

LD10 (FLASHING 24V LAMP, LAMP 2)

It must be normally switched off and it must switch on when the automation is in movement (both in closing and in opening)

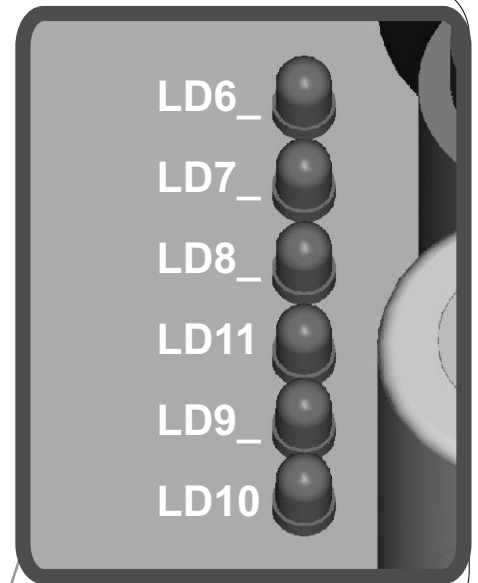

TR1 working time regulation

The trimmer TR1 regulates the working time for both the leaves. This time can be modified from 0 to 120 sec. Time increases turning the trimmer clockwise.

TR2 pause time regulation

The trimmer TR2 regulates the pause time (time for which the leaves stay opened before closing automatically). This time can be changed from 0 to 120 sec. Time increases turning the trimmer clockwise.

TR3 time regulation for the leaf delay in closing

The trimmer TR3 regulates the time of leaf delay in closing. This time can be changed from 0 to 16 sec. Time increases turning the trimmer clockwise.

NOTICE: To allow a correct reading of the trimmers do the adjustments with the gate closed.

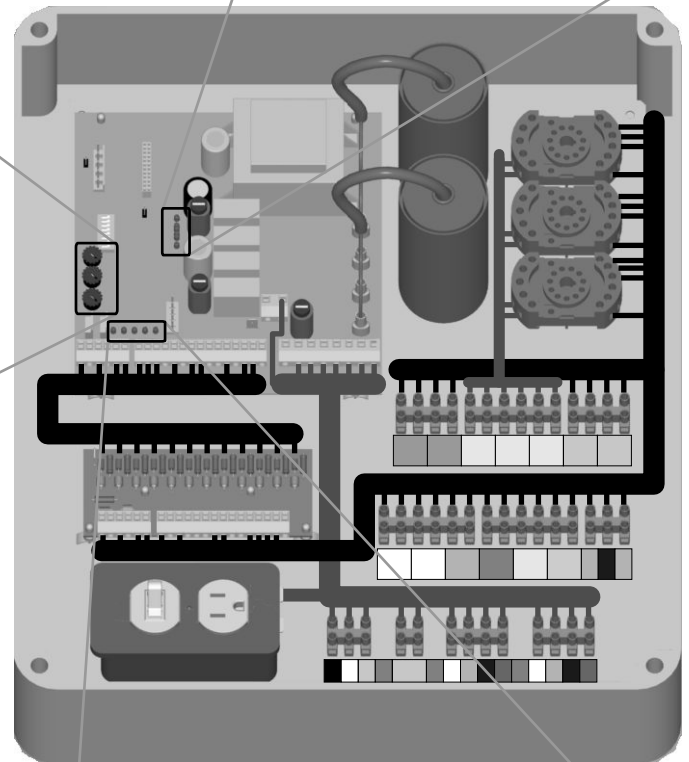
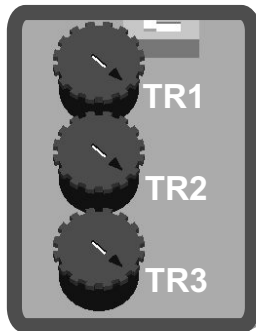

Diagnostic leds entrances

LD3 (STOP)

It must be normally switched on and it must switch off when a stop command is given

LD2 (PHOTO)

It must be normally switched on and it must switch off when the photocell is obscured

LD1 (SAFETY)

It must be normally switched on and it must switch off when a safety intervenes (for ex. Safety edge)

LD4(START)

It must be normally switched on and it must switch off when an opening command is given (for ex. Radio receiver, key switch, loop detector reader, etc)

LD5(PEDESTRIAN START)

It must be normally switched on and it must switch off when an pedestrian opening order is given to open a single leaf (for ex.key switch,keyboard etc)

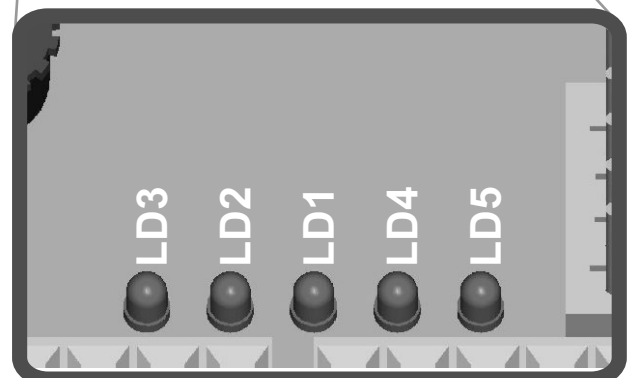



CN5: Expansion unit connector

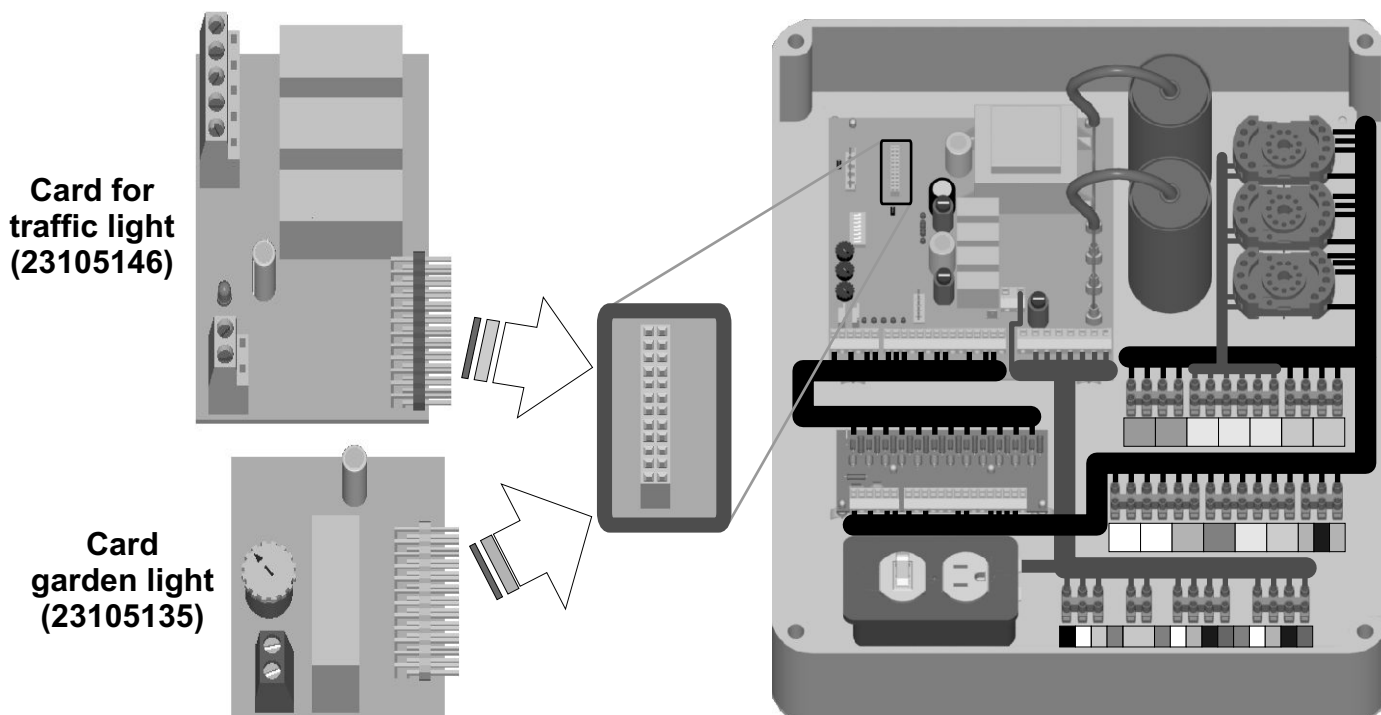

The **CN5** connector can be used to insert the **flashing lamp card (code 23105146)** to which it is suggested to combine always the **SEA two-lights flashing lamp (code 23105150)** or to insert the **garden lights card (code 23105135)** which manages 100W max with a changing time (trimmer) from 60 to 120 seconds.

CN4: Connector for autotest card for photocell

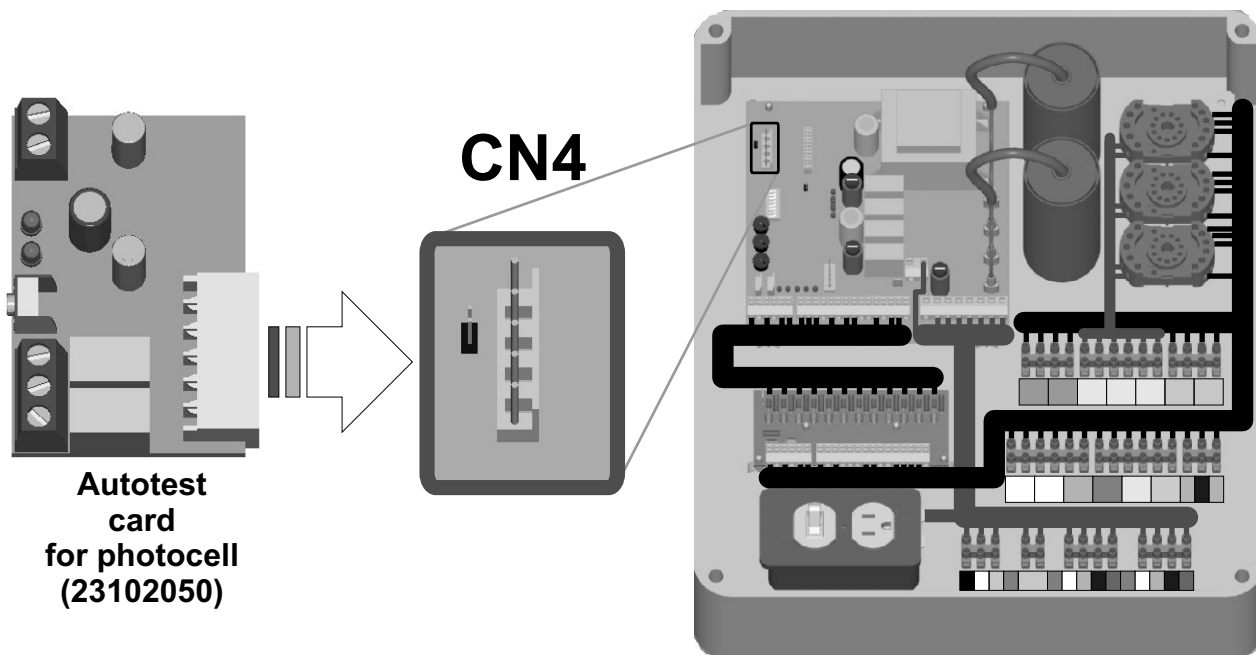

The **CN4** connector can be used only to insert the **autotest card for photocell (code 23102050)**; for the setting up make reference to the assembling instructions of the product itself. The autotest card mentioned above checks the good working of max two couples of photocells before every opening and closing. In case one of the two couples of photocells does not work correctly this card stops the equipment not allowing the opening or the closing.

NOTICE: in case the autotest card is used the **J2 jumper** must be disconnected; this will make the connector unusable.



**CONNECTING SCHEME OF THREE READERS OF MAGNETIC LOOP DETECTORS:
TWO OF THEM USED AS SECURITY DEVICE AND ONE AS FREE EXIT.**

CN6: Security, Flashing Lamp 24V Connector

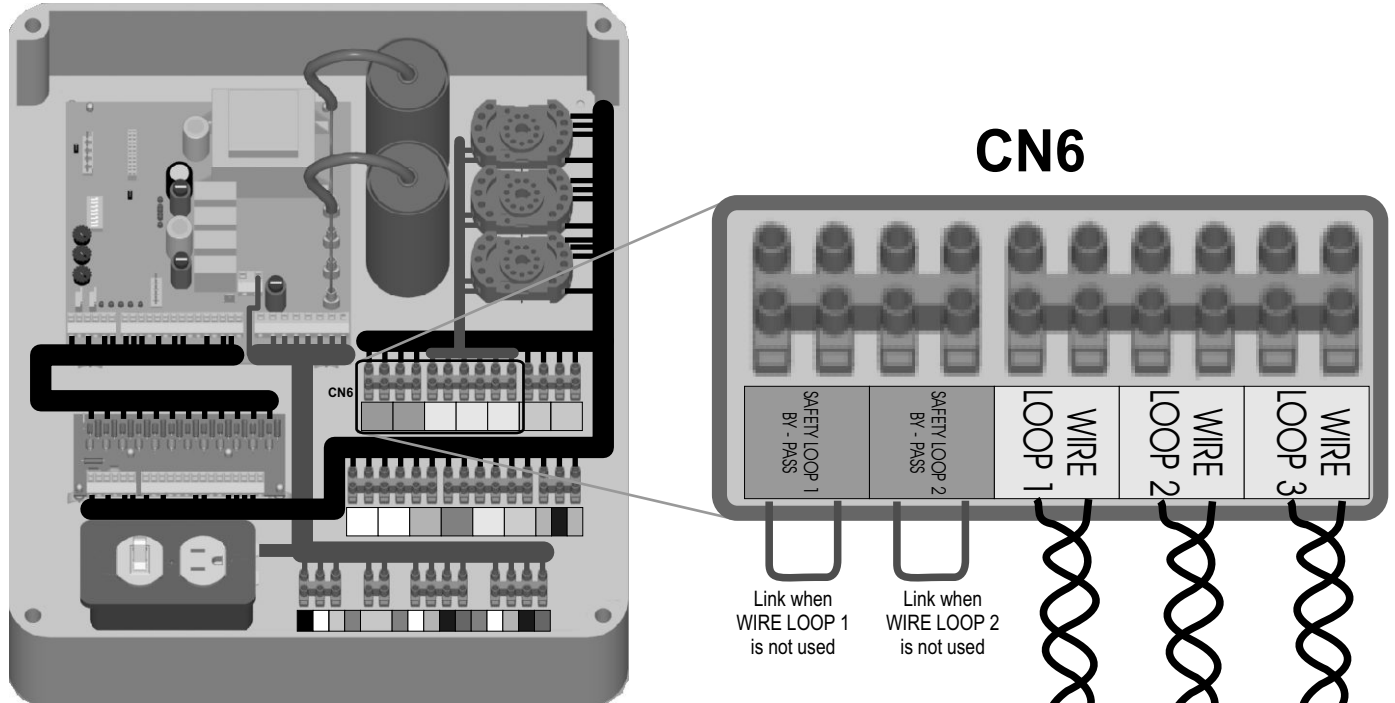

SAFETY LOOP 1

Cable layout of magnetic loop detector 1

When not used, link "SAFETY LOOP 1 BY - PASS"

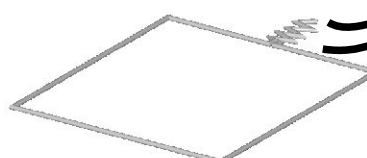

SAFETY LOOP 2

Cable layout of magnetic loop detector 2

When not used, link "SAFETY LOOP 2 BY - PASS"



FREE EXIT LOOP

Cable layout of magnetic loop detector





INSTALLATION SCHEME OF THREE READERS OF MAGNETIC LOOP DETECTORS: TWO OF THEM USED AS SECURITY DEVICE AND ONE AS FREE EXIT.

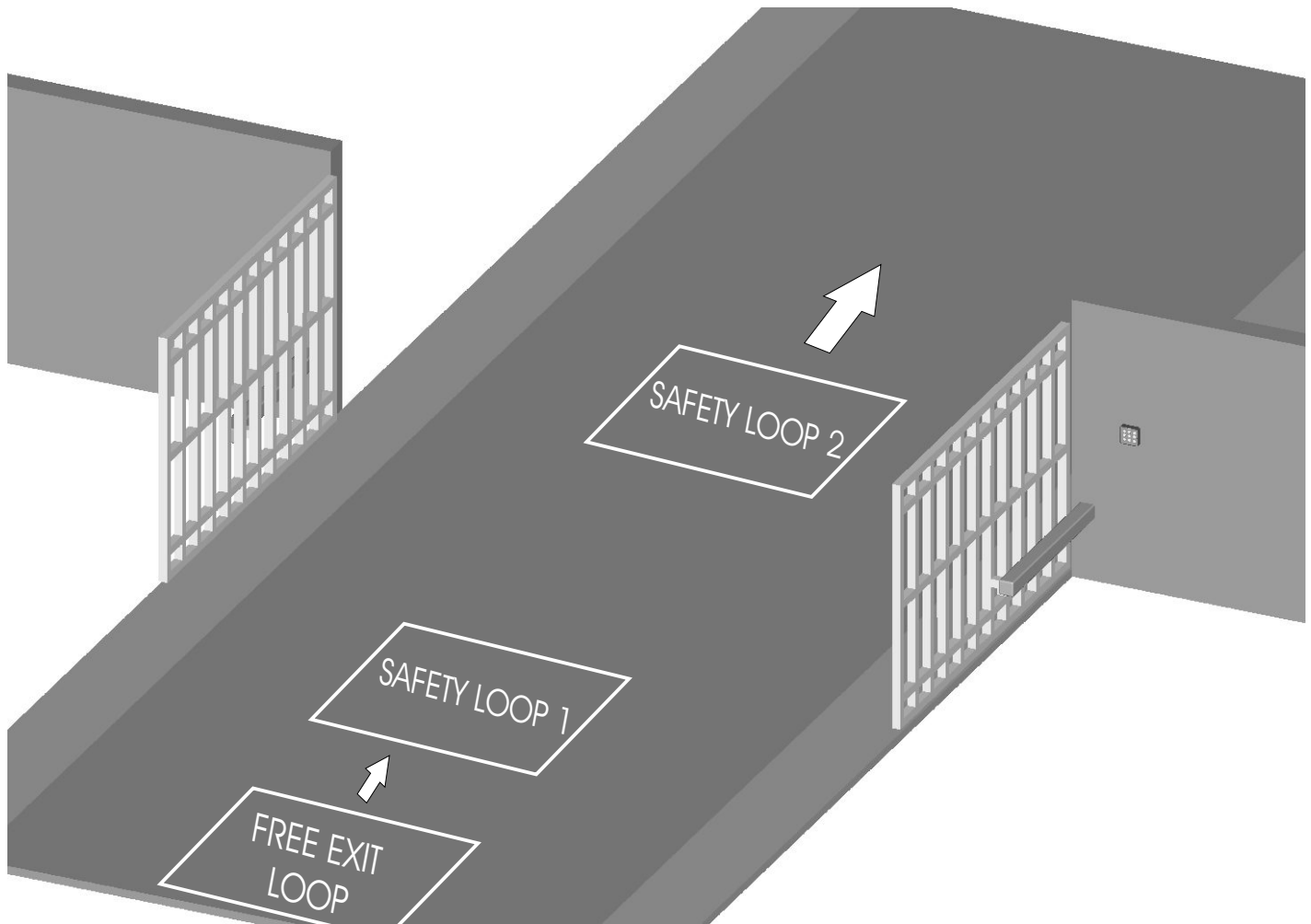

Notice: This kind of installation does not guarantee security to pedestrians.

SAFETY PRECAUTIONS

All electrical installation works should conform to regulations. A 16A - 0,030A differential switch must be incorporated into the source of the gate main electrical supply and the entire system must be properly earth bonded. Remember to run separate mains (115V) carrying cables (supply and motor). Also all low voltage controls (push button, photocell, radio etc.) cables should be run in separate ducts to the mains to prevent from mains interference.

Note: Use "cable clips" and/or "duct/box pipes" fitting close to the control panel box so to protect the interconnection cables against pulling efforts.

SPARE PARTS

To obtain spare parts contact:

SEA USA Inc. 2806 N.W. 79th AVENUE MIAMI, FL 33122

INTENDED USE

The 2302A series electronic control unit has been designed to be solely used as control unit for the automation of doors, gates, leaves and barriers.

LIMIT OF GUARANTEE

The 2302A series electronic control unit is guaranteed for a period of 36 months. The guarantee period starts from the date stamp printed on the unit. The 2302A series guarantee will be void if the unit has been incorrectly installed, not used for the purpose intended, tampered with or modified in any way. The validity of this guarantee only extends to the original purchaser of the unit.

NOTE: THE MANUFACTURER CAN NOT BE DEEMED RESPONSIBLE FOR ANY DAMAGE OR INJURY CAUSED BY IMPROPER USE OF THIS PRODUCT.