

HALF TANK AC BR (36V)

HYDRAULIC

Hydraulic swing gate operator for condominium use and for leaf lengths up to max **20 feet**

- Version (AC) lock in opening/closing
- Absolute encoder
- Piston stroke 270 mm / 10.6 inches

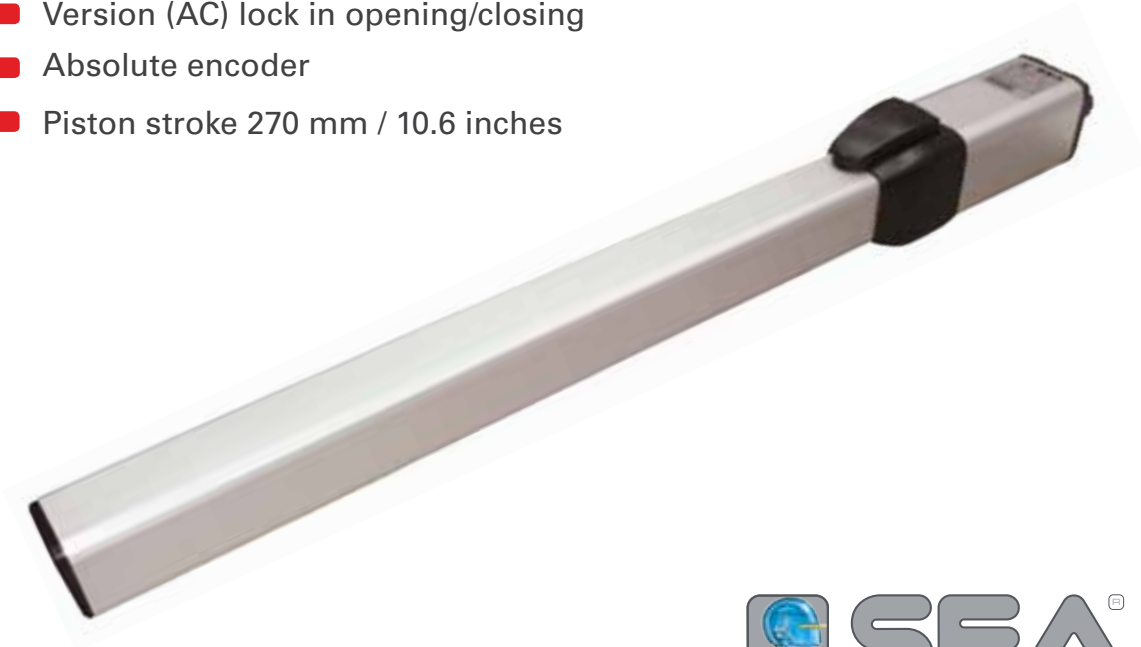

Optional metal standard release PLUS



POSITION GATE Absolute Encoder



Round joint for stroke adjustment

SPECIFICATIONS	HALF TANK BR
Power supply	115 V (±5%) 50/60 Hz
Motor power	260 W (36V)
Shaft Stroke	270 mm / 10.6 inches
Max duty cycles	100% (UNIGATE BR)
Working temperature	- 4° F + 131° F
Weight	12 kg /26 Lbs
Max leaf length	6,0 m / 20 feet
Opening degrees	90°- 125°
Shaft speed	1,5 cm/sec. max adjustable
Protection class	3R Type
Max thrust	6400 N

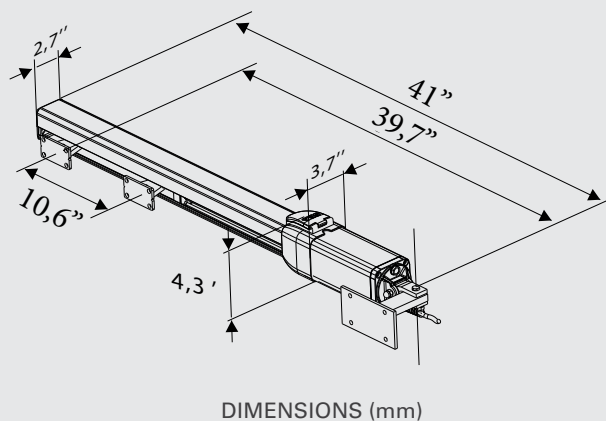

* (NOTE) Duty cycle is calculated as intermittence operating rate (%) on the 1st. hour



BRUSHLESS technology