

The Most Powerful Operator on the market

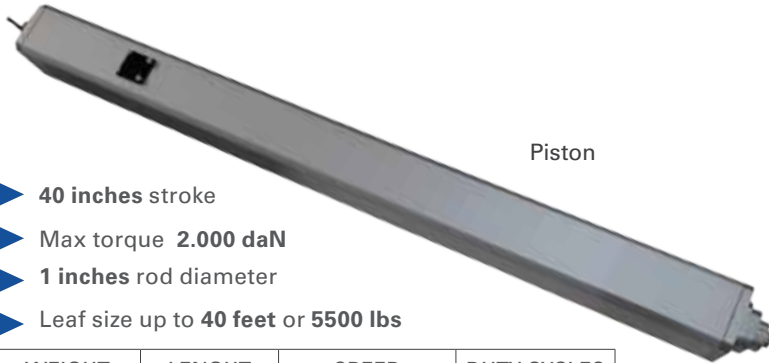

SUPER FULL TANK SP 40"

Hydraulic Swing Gate Operator for heavy duty gate applications



SPLIT
Piston - Pump

- ▶ 40 inches stroke
- ▶ Max torque 2.000 daN
- ▶ 1 inches rod diameter
- ▶ Leaf size up to 40 feet or 5500 lbs

WEIGHT	LENGHT	SPEED	DUTY CYCLES
5500 LBS	40 Ft	adjustable	continuous

UNIGATE - I *INVERTER technology*



PreWired UNIGATE Power Unit (single leaf)

SUPER FULL TANK 40"

Hydraulic Swing Gate Operator for condominium and industrial use max leaf length up to 40 feet

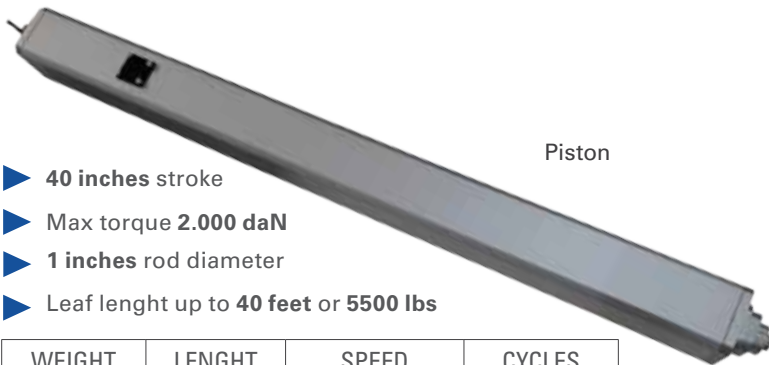

ALL - IN
Piston + Pump

- ▶ 40 inches stroke
- ▶ Max torque 2.000 daN
- ▶ 1 inches rod diameter
- ▶ Leaf lenght up to 40 feet or 5500 lbs

WEIGHT	LENGHT	SPEED	CYCLES
5500 LBS	40 Ft	adjustable	continuous

UNIGATE - I *INVERTER technology*



Release system protected by metal lock with release key at the inside



Round joint for stroke adjustment



Front flange in solid machined aluminium



Back flange in solid machined aluminium

SPECIFICATIONS	SUPER FULL TANK
Power supply	120V (±5%) 50/60 Hz
Power Consumption (W)	540 W
Operating T° range (F°)	-4°F to 131°F
Opening time 90° (sec)	40"sec.
Max Duty cycles	100% (UNIGATE)
Duty	Commercial-industrial
Protection class	IP55
Max leaf length	40 Ft
Max leaf weight	5.500 Lbs
Max opening angle (degrees)	90°/120°
Maximum force output	2000 daNm
Anti-crushing protection	By pass/Electronic
Limit switch	-
Slowdown	Hydraulic
Battery backup	STAR 400/800

UNIGATE - I

INVERTER technology



UNIGATE 2I (INVERTER)

- Digital control unit with LCD display
- Adjustable speed
- Adjustable acceleration/deceleration
- Continuous motor cycles
- High strength in slowdown
- Possibility to manage obstacle reverse

Integrated functions on the UNIGATE INVERTER

- 2 relay contacts
- 2 programmable GPIO outputs
- LE card on board for potentiometer
- Relay card on board
- PROBE heater card on board
- Management of two FV inverters for 2 motors or 2 PM modules for 4 motors
- Timer on board with buffer battery and management of 2 time bands
- 2 Ah switching transformer of which about 1.3 Ah free for other accessories

UNIGATE Pre Wired Box dimensions 15"x16"x6"(w)



Advantages:

- + Duty cycles
- + Torque
- + Speed (adjustable)
- + one model 90V to 265V

BASIC FULL TANK 10" VS SUPER FULL TANK 40"



Full Tank 10" stroke

Super Full Tank 40" stroke

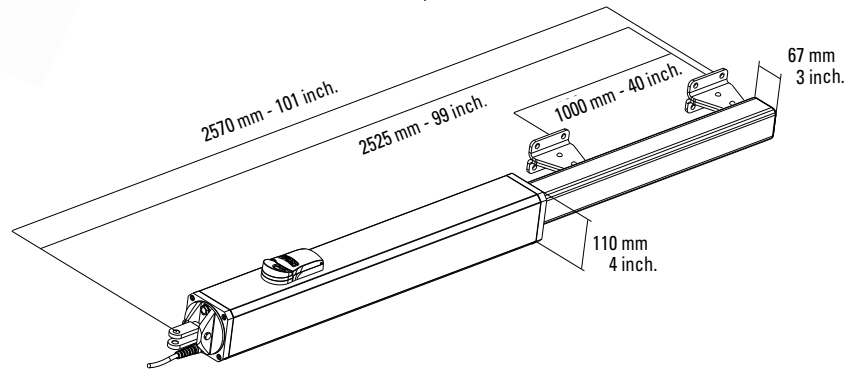
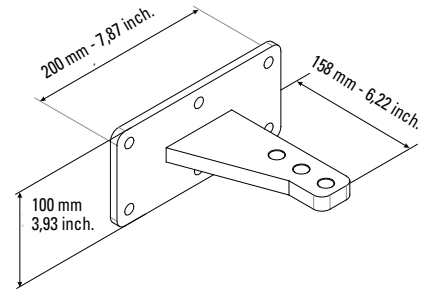
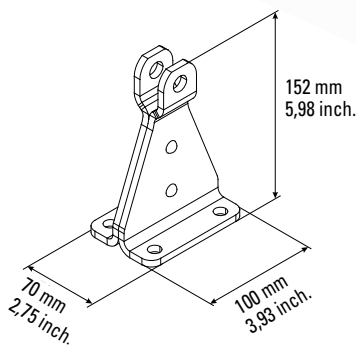

ACCESSORIES



Magnetic Lock



Kit Probe to manage low temperature + card LE + cable 6 Ft



Electric lock Counter-plate for horizontal or vertical mounting external and internal cylinder



Green oil (1 quarter of bottle)