



LEPUS BOX FAST INVERTER

Chain sliding motor for **HEAVY DUTY APPLICATIONS**

40 Ft and **2000 Lbs**

UNIGATE - I
INVERTER technology



- Ramps of acceleration and deceleration adjustable
- Speed adjustable



Unique manual release with lever (no crank needed)



Ball bearing wheels to grant a better performance



External manual release in option for power failures



Electric motor immersed in oil bath

- Opening up to 40 Ft and 2000 Lbs
- Electric motor and reduction gear are continuously immersed in oil bath allowing long last operation and intensive use
- Mechanical clutch in oil-bath as an anti-crush safety device
- Electronic clutch as an extra anti-crush safety device
- Reversing system in case of obstruction (ENCODER)
- Operator equipped with UNIGATE Inverter
- Ball bearing wheels
- Buzzer alarm

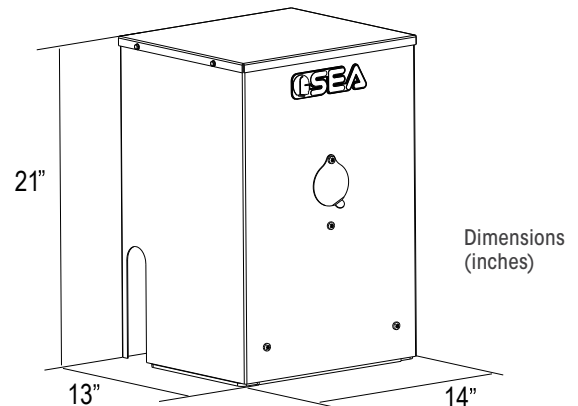

SPECIFICATIONS	LEPUS BOX
Power supply	120Vac
Power Consumption (W)	1/2 HP equivalent DC
Operating T° range (F°)	-4°F to 131°F*
Opening time 90° (sec)	1 1/2 Ft-sec
Duty cycles	90%
Duty	commercial
Max gate weight	2000 Lbs
Max Gate length (Ft)	40 Ft
Anti-crushing protection	Encoder/Electronic clutch
Operator weight	95 Lbs approx

UNIGATE - I

INVERTER technology



UNIGATE 2I (INVERTER)

- Digital control unit with LCD display
- Adjustable speed through ramps
- Adjustable acceleration/deceleration through ramps
- Continuous motor cycles because it does not heat up
- High strength in slowdown
- Possibility to manage obstacle reverse

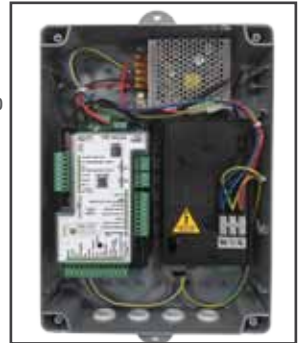

Integrated functions on the UNIGATE INVERTER

- 2 relay contacts
- 2 programmable GPIO outputs
- LE card on board for potentiometer
- Relay card on board
- PROBE heater card on board
- Management of two FV inverters for 2 motors or 2 PM modules for 4 motors
- Timer on board with buffer battery and management of 2 time bands
- 2 Ah switching transformer of which about 1,3 Ah free for other accessories

Advantages:

- + Duty cycles
- + Torque
- + Speed (adjustable)
- + one model 90V to 265V

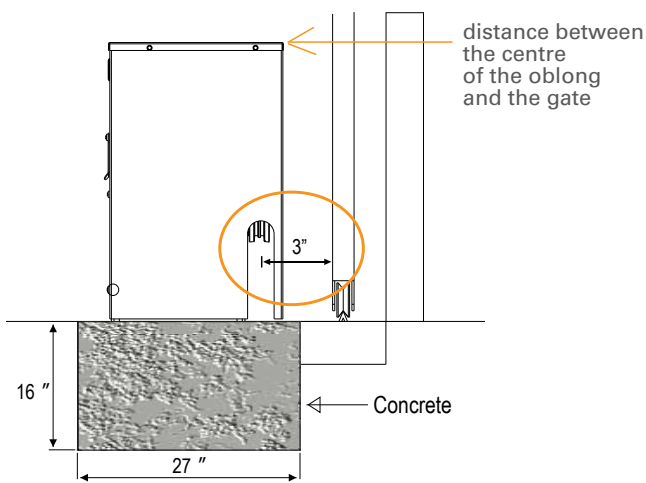

ACCESSORIES



PACKAGE LEPUS BOX
N.1 LEPUS BOX with control board
N.20 Ft of chain (type 40)
N.1 Receiver
N.2 Remote controls 433 Mhz
N.1 Installation accessories Kit
N.1 Installation instructions and general notice
N.1 Warning signboard
1 pc Pallet 18x17x H32 inches - 102 Lbs
12 pcs for pallet