



# HALF TANK

Hydraulic swing gate operator max leaf length up to **23 Ft** or **1500 Lbs**



- AC VERSION WITH LOCK IN OPENING AND CLOSING
- AVAILABLE MODEL WITH HYDRAULIC SLOWDOWN FOR A SMOOTH APPROACH OF THE LEAVES IN CLOSING



Battery back-up with fan cooling systems in option for AC motors

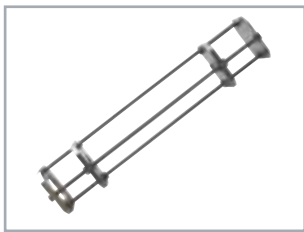

Positive stops in open/close as option



Hydraulic locks easy to change for maintenance



Round joint for stroke adjustment and front flange in solid aluminium



Back flange in solid aluminium



External release with SS cable and metal box, in case of power failure (optional)

- ▶ Standard, oscillating aluminium back fixing fork
- ▶ Hydraulic distributor made of machine aluminium bar
- ▶ Anti crushing guaranteed through by-pass valves for max. thrust adjustment
- ▶ Extremely silent with hydraulic reliability
- ▶ Version with hydraulic slowdown only in closing or in opening/closing
- ▶ 0.8 inches rod diameter
- ▶ Piston stroke 10.6 inches
- ▶ All-aluminium structure with high-resistance anodising treatment

SPECIFICATIONS	HALF TANK
Power supply	120V- 60Hz
Power Consumption (W)	300W
Operating T° range (F°)	-4°F to 131°F
Opening time 90° (sec)	8-12 sec with UNIGATE
Cycles/hour	55
Duty	Commercial
Protection class	IP55
Max leaf length	23 Ft
Max leaf weight	1.500 Lbs
Max opening angle (degrees)	120°
Maximum force output	640 daNm
Anti-crushing protection	by pass / electronic
Battery back up	STAR 400/800

# UNIGATE - I

## *INVERTER technology*



### UNIGATE 2I (INVERTER)

- Digital control unit with LCD display
- Adjustable speed
- Adjustable acceleration/deceleration
- Continuous motor cycles
- High strength in slowdown
- Possibility to manage obstacle reverse

### Integrated functions on the UNIGATE INVERTER

- 2 relay contacts
- 2 programmable GPIO outputs
- LE card on board for potentiometer
- Relay card on board
- PROBE heater card on board
- Management of two FV inverters for 2 motors or 2 PM modules for 4 motors
- Timer on board with buffer battery and management of 2 time bands
- 2 Ah switching transformer of which about 1.3 Ah free for other accessories



## Advantages:

- + Duty cycles
- + Torque
- + Speed (adjustable)
- + one model 90V to 265V

### Alternative boards:

Control Unit GATE 2 DG

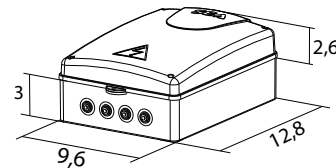

UNIGATE Pre Wired Box  
dimensions 15"x16"x6" (w)



MODEL	A	B	C
HT	41,33 in	39,37 in	10,62 in
HT with brake	43,66 in	40,23 in	10,62 in

### PACKAGE HALF TANK

#### N.1 HALFTANK

1 pc Carton box 32x9x5H inches - 28 Lbs

40 pcs for pallet

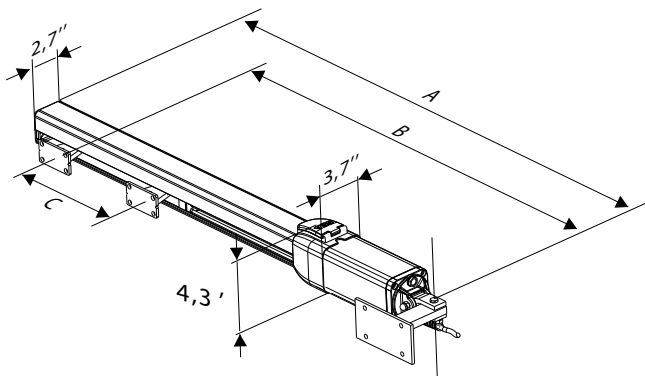
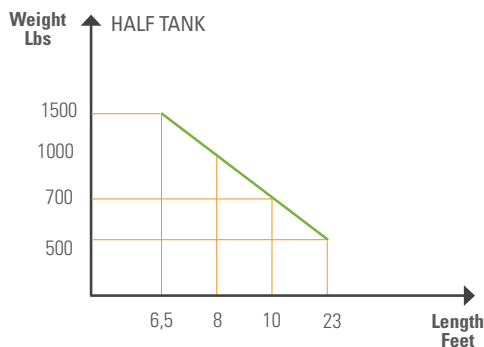

### ACCESSORIES



POSITION GATE  
Linear Encoder with  
accessories



Kit Probe to manage low  
temperature + card LE +  
cable 6 feet



Sea Com Video Wi Fi  
Wireless Video Intercom  
System



Green oil  
1 quarter of bottle



Electric lock Counter-plate  
for horizontal or vertical  
mounting external and  
internal cylinder



STAR 400/8000 Battery  
back-up Kit for 110V AC  
motors with fan cooling  
system 48V batteries not  
provided



Positive stops



External release with box



Metal release Plus with lock



BRA Adjustable back  
bracket to screw (2 pcs)



Reflex 10k 180°



SEA USA Inc.

10850 N.W. 21st Street - Unit 160 - 33172 Miami - Florida (USA)

Phone: +1-305.594.1151 - Fax: +1-305.594.7325

www.sea-usa.com