



# TAURUS BOX 1000 FAST

Residential electromechanical chain sliding operator for gate up to **1000 lbs**



**FAST opening 1 feet -sec**



**METAL CASE**



User friendly manual release with key



Ball bearing wheels



Mechanical limit switches screw adjustable



Encoder for obstacle reverse

- Encoder for obstacle reverse
- Receiver included
- Metal cover with cataphoresis treated box
- Slow down in opening/closing
- Ball bearing on the wheels
- Buzzer alarm
- Digital control board GATE 1 DG
- Long lasting yellow zinc metal chassis
- Duty Cycles\*: 40% depending on gate size and installation

SPECIFICATIONS	TAURUS BOX
Power supply	120 V (±5%) 50/60 Hz
Power	300 W
Absorbed current	2,45 A
Thrust force	from 0 to 35 Nm
Leaf speed (pinion Z20)	Adjustable
Use rate	40%
Max gate weight	1000 lbs
Max gate opening	25 ft
Type of limit switch	electromechanical
Operating T°	from -4°F to 131°F
Operator weight	73 lbs
Protection class	IP 55
Opening time	0,75 feet/sec

## GATE 1 DG

- Management of one 115 Vac motor
- Adjustable slowdown in opening and closing
- Adjustable pedestrian opening
- Led warning lamp
- Connector for radio RF receiver plug-in
- Working time self-learning
- Encoder management
- Simplified programming with buttons and display
- Inversion on obstacle with encoder
- Balanced or standard safety edge management
- Separate torque adjustment for opening and closing
- Programming through JOLLY 3 palm also
- Automatic, security and step by step type 1, step by step type 2, 2 buttons, dead-man logics
- Motor inversion and limit switch (right/left hand mounting)
- Automatic closing adjustment
- Start in pause adjustment
- Prepared for Master/Slave function
- Adjustable courtesy light output up to 4 minutes
- Setting number of cycles for assistance
- Settable photocell inputs
- Extractable terminals
- Photocell self-test
- Management of photocells 10K
- ...and many other functions

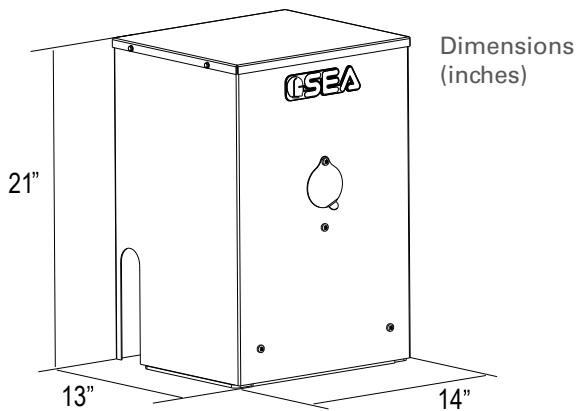
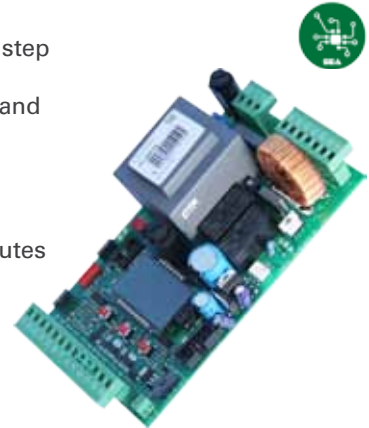

Dimensions (inches)

### PACKAGE TAURUS BOX 1000 FAST

N.1 TAURUS BOX BOX 1000 FAST with GATE 1 DG control board
N.20 Feet of chain (type 40)
N.1 Receiver
N.2 Remote controls 433 Mhz
N.1 Installation accessories Kit
N.1 Installation instructions and general notice
N.1 Warning signboard
1 pc Pallet 18x17x H32 inches - 86 LBS
12 pcs for pallet

### ACCESSORIES



Case in stainless steel

